

TLW120E150-HD4C TLW120E150-HD7C

Horizontal Double Rail Electronic Surface Mount Transformer

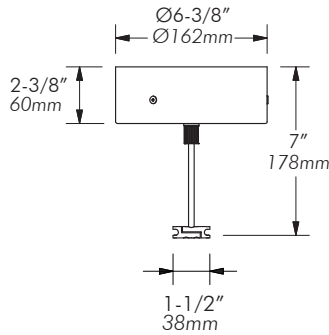

*Custom length available

Material: Steel case and copper tube with electroplated finish

Mounting: Surface mounts to standard J-box.

Electrical: 100% Duty cycle. Auto reset circuit protection. Can only be used on MP cable system. Stem can be used as a cable support. Can be dimmed using electronic low voltage dimmers (i.e. Lutron Diva).

AC Input Voltage: 120V, 60Hz

DC Output Voltage: 12V

Output Wattage: 150W Max. (TLW120E150-HD4C)
150W Max. (TLW120E150-HD7C)

Maximum Load: Depends on wattage of fixture

Power Factor: 95% Min

Typical Efficiency: 80%

Short Circuit Protection: Yes

Overload Protection: Yes

Operating Temperature: -10~50°C (14~122°F)

Maximum Case Temperature: 65°C (149°F)

Humidity (Non-Condensing): 5%~95%

Weight: 3lb / 1.4kg

Approval: Dry locations. Approved to UL standards by CSA/US.



Type:

Project:

Modified:

Quantity:

Notes:

CODE	WATTAGE	MOUNT	OFFSET	CANOPY	FINISH
TLW120E	150	HD		C	
	150 = 150W	HD = horizontal double rail	4 = 4"/102mm from ceiling to bottom of cable 7 = 7"/178mm X = custom length	C = circular	MC = matte chrome BN = brushed nickel